

Study on Passenger Flow Control of Subway Hub based on Anylogic

Ran Chen^{1,*}, Yuhan Li²

¹School of Public Security, Jiangsu Police Institute, Nanjing, China

²Suzhou Public Security Bureau, Suzhou, China

*Corresponding author: chenran@bjtu.edu.cn

Keywords: Passenger Flow Control; subway Hub; Anylogic

Abstract: The rapid increase of subway passenger flow during holidays brings great pressure to subway operation organization. Subway stations are usually located underground, with closed space and complex structure, long evacuation routes and poor ventilation and lighting conditions, making evacuation more difficult in emergency situations. In this paper, Anylogic simulation software is used to simulate evacuation of a subway station during holidays. Based on the simulation results, an effective method to optimize passenger flow evacuation is proposed.

1. Introduction

Helbing [1] et al. established a social force model in the process of emergency evacuation, and studied the evacuation situation of pedestrians in panic state through the driving force of pedestrians themselves. Pan et al. [2] developed MASSEgress, a structure of personnel evacuation model, which is based on a multi-agent system and analyzes external physical factors affecting personnel behavior by setting different independent individuals. Henderson [3] proposed a fluid mechanics model and compared pedestrian movement to the flow of gas or liquid. Cruz, F.R.B [4] and other scholars applied the queuing model M/G/ C/C model to the evacuation model so as to quantitatively analyze the evacuation bottleneck in pedestrian evacuation. Fraser-Mitchell [5] and other scholars applied CRISP model to assess fire evacuation risk, so as to calculate evacuation risk in different areas. Wang H et al. aim to develop and establish an evacuation model that considers the OCEAN personality psychological traits to improve the credibility of the emergency pedestrian evacuation simulation [6]. Chen J et al. develop a four-dimension parameter system that includes Required Safety Egress Time, Average Evacuation Time, Average Waiting Time, and Average Moving Distance to quantify the evacuation performance from four aspects [7]. Combining the total escape time, the total contact time with fire, and the total contact time with smoke, Chen N et al. [8] proposed a calculation formula on emergency escape capability.

2. The basic fundamental of Social Force Model

2.1 The formulations of social force model

The social force model, proposed by German scientists, describes the individual's will and the environment's effect on people respectively by self-drive and force. The final walking vector speed is determined by the comprehensive influence of self-driving force and interaction force shown in Figure 1. This model can describe and explain the phenomena of outlet congestion and fast is slow.

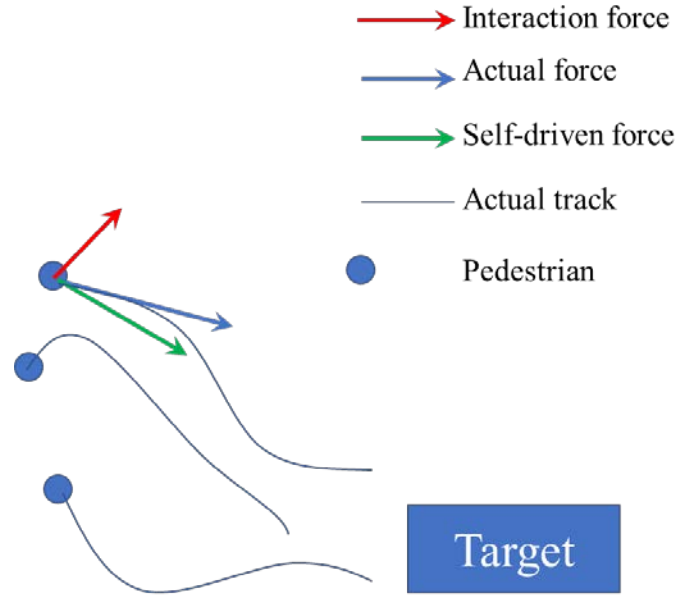

Figure 1. Social Force Model Structure.

The general model of social force consists of two basic forces, which are:

(1) Pedestrians have desired directions e towards the targets, desired velocity v_0 . So the actual velocity v vector would get near to $v_0 e$.

(2) Pedestrians will be influenced by other pedestrians and obstacles in a certain range in the actual walking process, which is described by the interaction force, including person forces and obstacle forces.

$$F_{social} = F_{self-driven} + F_{interaction} \quad (1)$$

$$F_{self-driven} = \frac{1}{\tau} (v_0 e - v) \quad (2)$$

$$F_{interaction} = F_{person} + F_{obstacle} \quad (3)$$

$$F_{person} = \{A_i \cdot \exp[(r_{ij} - d_{ij})/B_i] + k \cdot (r_{ij} - d_{ij})\} n_{ij} + k \cdot g(r_{ij} - d_{ij}) \cdot \Delta v_{ij}^t \cdot t_{ij} \quad (4)$$

$$F_{obstacle} = \{A_i \cdot \exp[(r_i - d_{iw})/B_i] + k \cdot g(r_i - d_{iw})\} n_{iw} - k \cdot g(r_i - d_{iw}) \cdot (v_i \cdot t_{iw}) t_{iw} \quad (5)$$

The model of social force model is based on Newtonian dynamics, and the expressions of each force reflect the different motivations and influences of pedestrians. Individual's actual behavior is affected by individual's subjective consciousness, inter-individual and obstacle, which can be equivalent to the effect on the individual.

2.2 The simulation software Anylogic based on social force mechanism

The pedestrian library in Anylogic could simulate the pedestrian size, speed, acceleration and deceleration, field of vision, walls, stairs and other factors. The social force model is adopted at the bottom of the pedestrian library to accurately simulate the influence of human psychology on actions. Finally simulation results would show the bottleneck area of congestion.

3. Results

3.1 The establishment of simulation model

We established the simulation model of parts of Nanjing South Railway subway Station in Anylogic, including platform equipment layout and passenger service process in Figure 2. We conduct two simulations of passenger avocation in Nanjing South Railway Subway Station, with and without subway security personnel respectively.

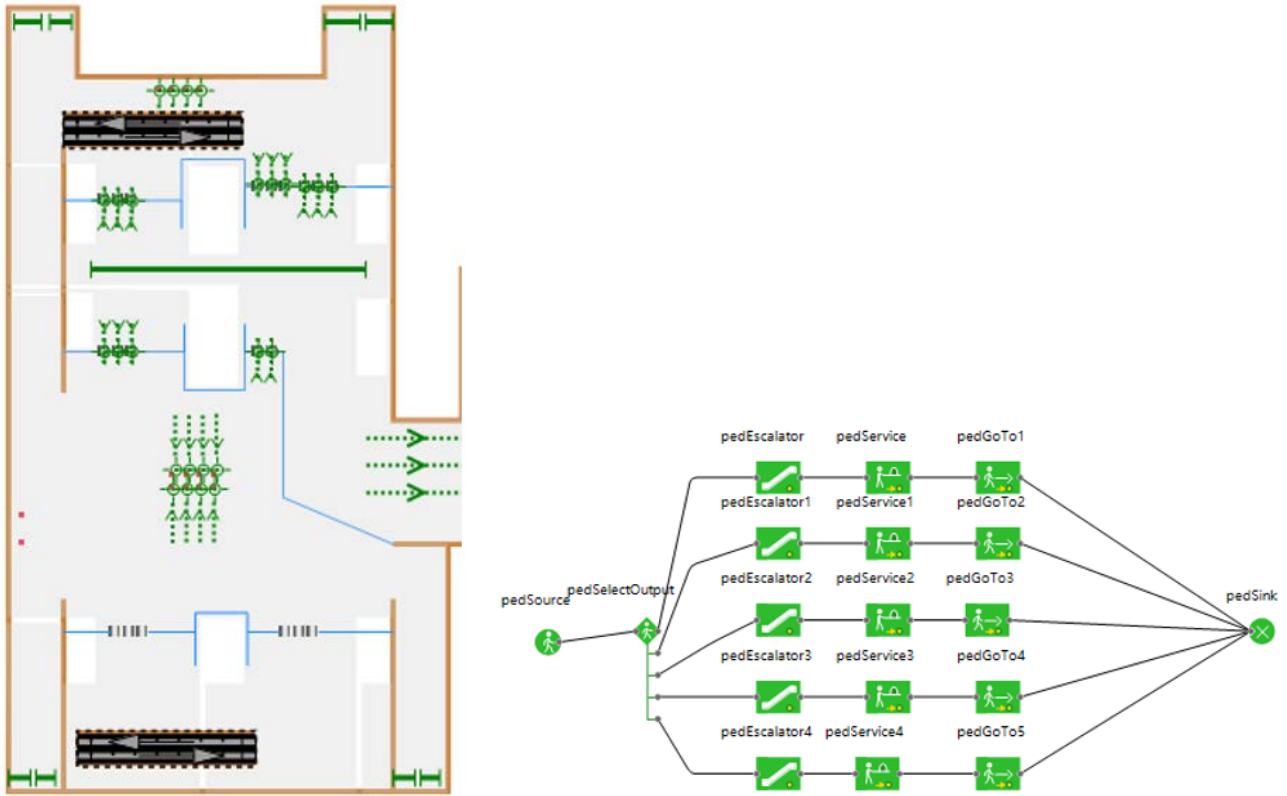

Figure 2. The Establishment of Simulation Model in Anylogic.

3.2 Analysis of experimental results

By directing passengers to other escalators by subway security personnel, the originally crowded passenger flow (black circle in the left graph of Figure 3) was dispersed. It slightly aggravated the congestion in other places, but greatly alleviated the gathering of people at the black circle mark and reduced the possibility of tramping in this area (shown in black circle in the right graph of Figure 3).

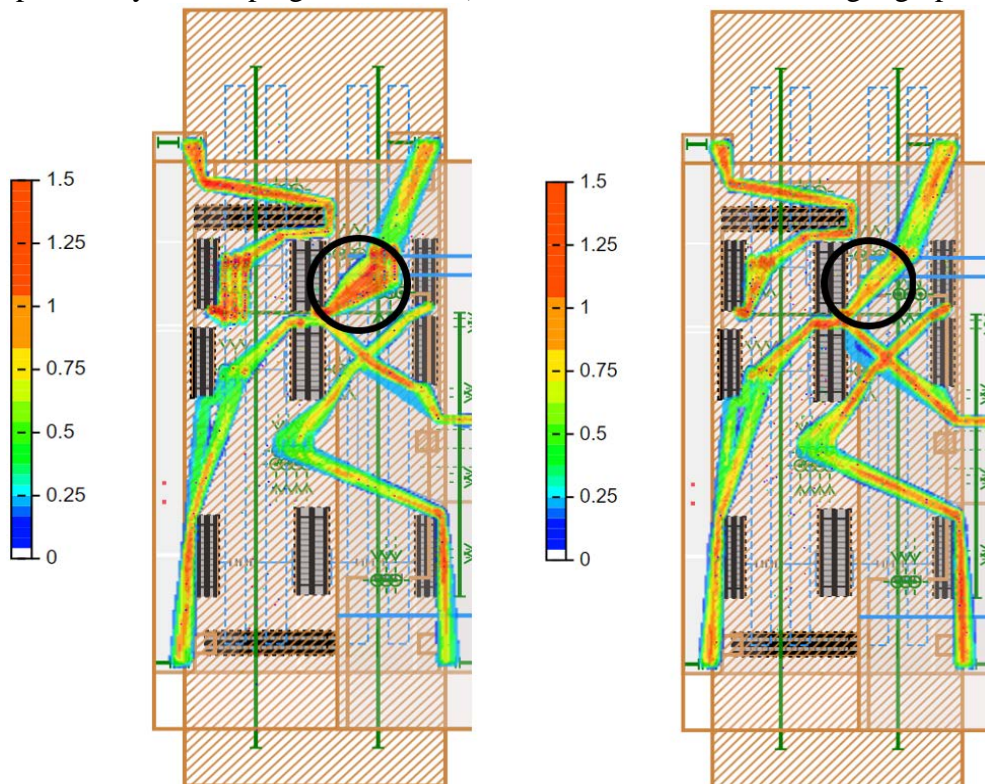

Figure 3. Comparison between two simulations.

From the comparison between two simulations in Figure 3, it shows that the induced evacuation effect of subway safety personnel is significant, especially in the case of sudden large passenger flow such as holidays.

4. Conclusions

This paper uses Anylogic software to simulate evacuation processes based on the social force model taking Nanjing South Railway Station as an example. Two simulation results of passenger emergency evacuation verify that the timely guidance of subway safety personnel has great effect on alleviating congestion bottleneck.

Acknowledgement

The authors gratefully acknowledge the financial support from Jiangsu Police Institute.

References

- [1] Helbing D, Farkas I, Vicsek T. Simulating dynamical features of escape panic [J]. *PubMed*, 2000, 407 (6803).
- [2] Xiaoshan Pan, Charles S. Han, Ken Dauber, Kincho H. Law. A multi-agent based framework for the simulation of human and social behaviors during emergency evacuations [J]. *Springer-Verlag*, 2007, 22 (2).
- [3] Henderson. Simple theory for the critical adsorption of a fluid. [J]. *PubMed*, 1985, 32(4).
- [4] F.R.B. Cruz, J. MacGregor Smith, D. C. Queiroz. Service and capacity allocation in M/G/ c / c state-dependent queueing networks [J]. *Computers and Operations Research*, 2003, 32(6).
- [5] Sung-Han Koo, Jeremy Fraser-Mitchell, Stephen Welch. Sensor-steered fire simulation [J]. *Fire Safety Journal*, 2010, 45(3).
- [6] Wang H, Xu T, Li F. A Novel Emergency Evacuation Model of Subway Station Passengers Considering Personality Traits [J]. *Sustainability*, 2021, 13(18): 10463.
- [7] Chen J, Liu C, Meng Y, et al. Multi-Dimensional evacuation risk evaluation in standard subway station [J]. *Safety science*, 2021, 142: 105392.
- [8] Chen N, Zhao M, Gao K, et al. Experimental Study on the Evaluation and Influencing Factors on Individual's Emergency Escape Capability in Subway Fire[J]. *International journal of environmental research and public health*, 2021, 18(19): 10203.